

## Study and Application of Flotation in Schemes for Waste Water Purification

**Viktor Georgijevch Ponomariov**

*“Stroyengineering SM” L.L.C., Russia*

*(received in November, 2009, accepted in December, 2009)*

The paper analyzes the factors influencing water treatment by means of flotation. Author has come to a conclusion that one of the indices revealing flotation efficiency is surface tension of the water phase. The paper presents dependencies of this index on some parameters. In addition, the paper analyzes applicable constructions of flotators. Preference is given to impeller flotation due to its suitability to application.

Key words: waste water, flotation

The process of water treatment by means of flotation is based on adsorption of gas bubbles upon the surface of contaminants, which makes the contaminants rise up to the surface and form there a foam layer easily removable from the facility.

During the last 30 years the flotation method has found ever-widening applications due to its advantages compared to a simple sedimentation: waste water suspensions (emulsions) are separated at higher speed while the isolated contaminants gathering as foam on the water surface in the facility have lower humidity compared to the sediment removed from the sedimentation basins hydraulically. At the same time, the flotation process applicability depends on the surface properties of the contaminants featured by limiting wetting angle  $\theta$  (Fig. 1) which determines their hydrophobic and hydrophilic behaviour. Wetting ability of a fluid depends on its polarity and decreases as the latter grows. Particles with small  $\theta$  value are referred to hydrophobic and can be separated from water by flotation. Oils and petroleum products are primarily referred to such substances. When being sorbed on the surface of hydrophilic contaminants, molecules of these reagents are oriented in the adsorption layer by non-polar hydrocarbon groups into outside ambient, thus adding hydrophobic properties to the surface.

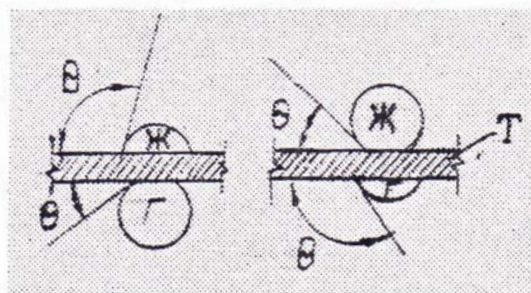

Fig. 1. Limiting wetting angle: a) on dry hydrophilic surface; b) on hydrophobic surface; T – solid body; Г – gas; Ж – liquid;  $\theta$  – wetting angle

On the other hand, a parameter featuring the wetting ability of the liquid phase of waste water as well as of any other liquid is surface tension  $\sigma$  whose growth makes increase the flotation effect [1].

Thus, the efficiency of a flotation process of contaminant separation from water depends on their surface behavior, on the properties of the waste liquid as well as on the inter-attraction forces between the gas bubble and the contaminant particles, on their collision frequency determined by hydrodynamics of flows in the facility, on the size of gas bubbles and contamination particles and, in addition, on the

conditions of bubble formation on the liquid-particle phase interface.

Several types of flotation are known which differ in the methods of preparation of the discontinuous gaseous phase being the base of this process, namely:

- foam separation, when the gas (air) is dispersed while going through the perforated membrane, pipeline, porous partition, etc.;
- pressure flotation, when before delivery to the open reservoir (flotation chamber) the water is saturated with gas (air) under pressure in a separate vessel (saturator). Due to reduction of air pressure and solubility in the open reservoir (flotation chamber), the air evolves from water in the form of small bubbles that are sorbed on contaminants with low wettability;
- vacuum flotation, which is a reverse process of the pressure flotation for preparation of the dispersed air-water phase;
- impeller flotation, where the air phase is realized due to the air inflow into a funnel cavity of air, which is formed due to spinning of a rotor (mixer) inside a fixed perforated stator;
- electrical flotation. In this case the finely dispersed phase is formed as a result of liquid phase (water) dissociation in the electrical field between the electrodes.
- chemical flotation, when the gas phase is formed in consequence of chemical reactions.

Applicability of the aforementioned methods depends on local conditions, properties and volumes of waste water and contaminants therein contained. More applications have been found by pressure and impeller flotation.

The advantage of pressure flotation is a more equal size of air bubbles forming in the air-water phase ( $d = 0.5$  to  $1.5$  mm); on the other hand, this method requires the additional equipment: high pressure pumps ( $P = 4.5$  to  $5.0$  gauge atm), pressure vessel (saturator), injector or compressor. Besides, the air phase volume is restricted by water solubility of the gas (air), see Fig 2.

Impeller flotation is carried out in the same volume with impeller particles placed therein and requires no additional equipment. The volume of air entrained for preparation of the air-water phase is much bigger than in pressure flotation. However, the dispersion composition of air bubbles may vary within a wide range ( $0.3$  to  $5$  mm) and to a greater degree depends on the properties of aquatic medium, such as surface tension  $\sigma$ . This parameter dictates the applicability of an impeller flotation method. At low  $\sigma$  values the dispersion composition is featured by large-sized bubbles ( $d = 3 \dots 5$  mm) and, hence, by the small surface area of contaminant adsorption, therefore the effect of a contaminant separation process decreases or is off at all.

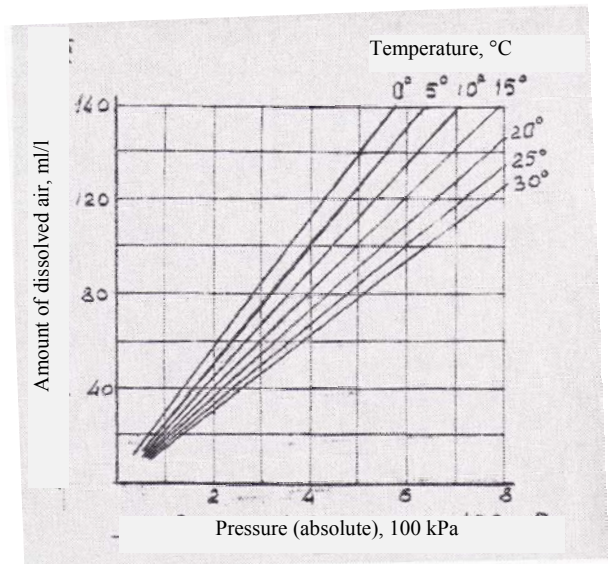

Fig. 2. Water solubility of air against pressure and temperature

Relationship between surface tension and physical parameters of water and concentration of suspended and dissolved contaminants has been studied in laboratory conditions. Diagram in Fig. 3 shows the main dependencies obtained. Thus, it has been established that  $\sigma$  decreases with the growing temperature, which can entail reduction in efficiency of purification in the flotation chamber. The growth in salinity within  $5.0$  g/l increases the surface tension, which demonstrates the applicability of flotation for purification of salt-containing waste water.

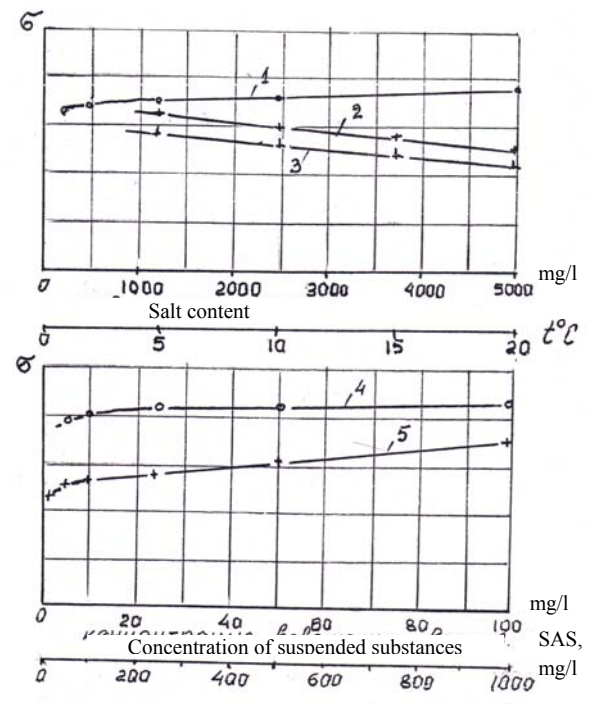

Fig. 3. Relationship between surface tension ( $\sigma$ ) and: 1 - salt content, 2 - temperature (mains water  $C = 200$  mg/l), 3 - temperature (distilled water), 4 - suspended substances, 5 - surface-active substance (soap).

Certain increase has been noted in  $\sigma$  value when changing the content of finely-dispersed (clay fraction) of suspended substances within the limits up to 100 mg/l (Fig. 3, curve 4). More notable increase in  $\sigma$  value has been observed with changing the concentration of surface-active substances (SAS, Fig. 3, curve 5). The growing  $\sigma$  value is accompanied by a decreasing size of dispersed air bubbles, an increasing surface area of contaminants sorption and, hence, by enhancing the efficiency of their separation.

All the aforementioned parameters influence the air phase dispersivity which determines the flotation process efficiency, especially with impeller flotation. Apparently, that is why in most cases the application of pressure flotation is more efficient.

Water aeration in pressure flotation is carried out immediately in front of the flotation chamber, in this case the whole flow or its part (30% to 70%) is aerated or, which most often takes place in practice, the recirculation stream (usually 50% volume) is aerated after it has passed through the flotation chamber. In the latter case it is expected the recycling of reagent remaining in water as well as the lack of petroleum products (oils) dispersion that can take place upon aeration of a part of the incoming water volume. However, in this case the dimensioning of the flotation chamber must account for the increase in the delivered recirculation water flow rate, which is referable to drawbacks of this method.

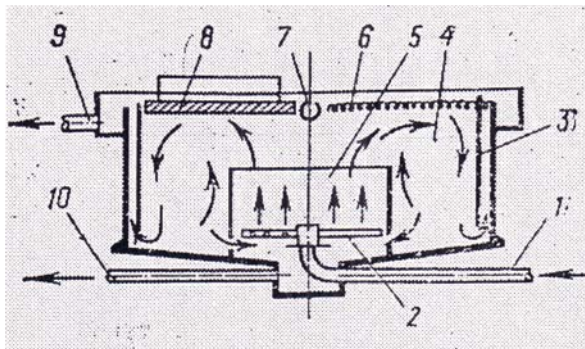

Fig. 4. Typical flotator of Soyuzvodokanalproyekt: 1 – water delivery with reagent and air-water mixture; 2 – distribution device (Segner-wheel); 3 – semisubmerged partition; 4 – flotation zone; 5 – ring-shaped partition; 6 – foam; 7 – radial foam-collecting tray; 8 – scraper; 9 – purified water outlet; 10 – washout and sediment withdrawal pipeline

The most often used design of a pressure flotation chamber is shown in Fig. 4. After primary mechanical treatment the waste water flow is taken through a pipeline to a mixing chamber in front of which the reagent solution is delivered in the pipeline together with the air-water mixture of recirculation flow that has passed the saturator. The incoming flow is distributed at the bottom of the chamber central part confined by a ring-shaped partition. The flow inlet is carried out through a distribution device in the form of a Segner-wheel. Due to pressure reduction the finely-dispersed air bubbles are separated from the

flow and simultaneously the flotation process begins. The aerated flow rises up and spreads in a radial direction towards the periphery. Having reached the semisubmerged partition, the flow goes down and under the partition and then up, running over the spillway into a ring-shaped water-intake tray. Flotated contaminants are accumulated in the form of foam on the water surface and are removed by a rotating scraper into a radial foam-collecting tray and are then moved along it out of the facility.

The drawback of this design is a small useful volume being about 25% according to investigations. The rest of the volume is occupied by recirculation flows zones and practically does not participate in the purification process. That is why each such flotator has a possibility to enhance the effective-volume utilization factor and, hence, to increase the output capacity and efficiency of purification.

A higher purification degree is provided by the design shown in Fig. 5, which is a flotator supplemented by a floc formation chamber according to developments by Dr. I.N Myasnikov.[2]. As demonstrated by the studies conducted in one of oil refineries, the degree of purification of oily waste water with the use of aluminum oxychloride as a reagent has increased considerably: residual content of petroleum products did not exceed 5 mg/l compared to 15 – 25 mg/l before the modernization.

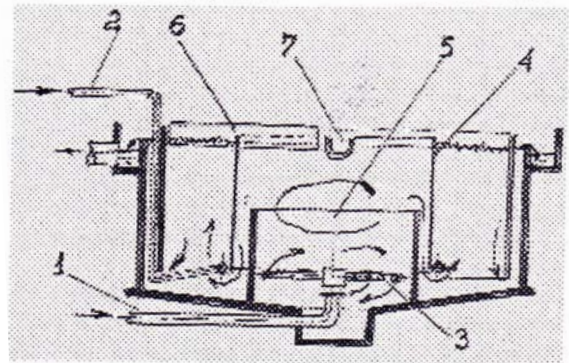

Fig. 5. Modernized typical flotator: 1 – delivery of waste water with coagulant solution; 3 – distribution device; 4 – rotating cylindrical partition; 5 – floc formation chamber; 6 – scraper; 7 – foam-collecting slotted pipe

In the design [3] developed by VNIIVODGEO Institute (Fig. 6) the volume utilization efficiency is increased up to 70% - 80%. It is achieved by adding the coaxial cylindrical partitions which divide the volume into separate zones. Inlet and distribution of the aerated water flow is carried out also by the Segner-wheel. The aerated flow rises up and, having reached the water surface and freed from air bubbles, moves down meeting the upward air-water flow. The studies show that the additional purification is obtained in the counterflow. This design provides a higher purification effect and considerably smaller dimensions, which allows suggesting its application to local water treatment and installing directly onsite.

The increased water purification effect is provided by *Croft* flotator due to “zero” velocities of the outgoing flow with reactive water intake to the flotation chamber when the flow outlet velocity is equal to the velocity of reverse-direction movement of the distribution device. Similar solution was suggested in 1959 by Professor I.V. Skirdov [4] in “a settler with rotating collection-distribution device”.

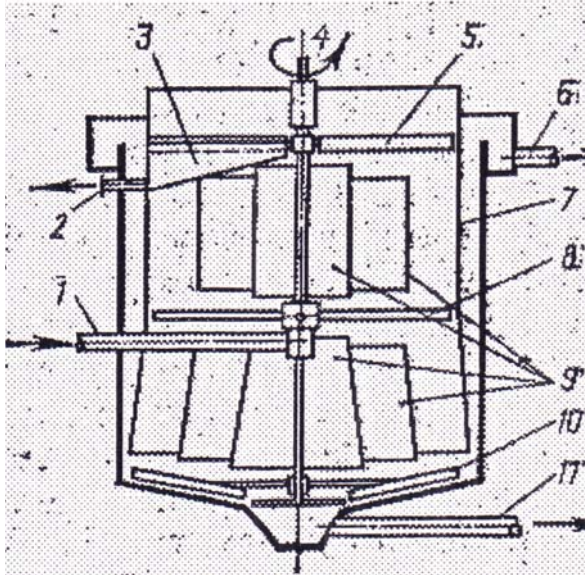

Fig. 6. VNI VODGEO flotator. 1 – waste water and air-water mixture feed pipeline; 2 – foam products outlet pipeline; 3 – foam-collecting tray; 4 – drive; 5 – scraper; 6 – purified water outlet pipeline; 7 – semisubmerged partition; 8 – rotating distribution device; 9 – coaxial partitions; 10 – slurry scraper; 11 – slurry pipeline

Another advantage of *Croft* design is a small depth of a flotation chamber which allows mounting the multistage flotators. At the same time, attention is drawn to the fact that from the company’s supplied data on the flotator’s dimensions, its output rate and process duration, it follows that the hydraulic size of the air bubbles released in the flotation chamber is 2.7 mm/s. These are big enough bubbles having a small sorption surface in the whole volume of the air-water phase. We have established that the flotation chambers should be designed for emission of bubbles whose hydraulic size is from 0.8 to 1.0 mm/s.

“Stroyengineering SM” L.L.C. has developed and launched the production of a factory-made flotator combined with the flock formation chamber (Fig. 7) with 2 to 6 m diameter.

Presently, much attention is given to the application of impeller flotation which does not need additional equipment and is simple to use. Besides, the design of impeller dispersers allows their cheap modernization or adding to the already existing settlers, oil traps, grease catchers or other tank facilities used for water purification from

contaminants with specific weight  $\rho \leq 1.0 \text{ g/cm}^3$  or low-wet suspended matter.

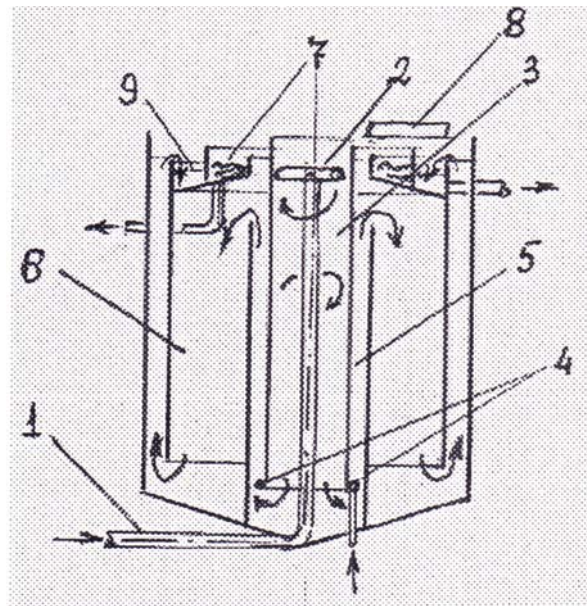

Fig. 7. Pressure flotator, “Stroyengineering SM” L.L.C. 1 – water-reagent mixture feed pipeline; 2 – distribution device; 3 – flocc formation chamber; 4 – ring-shaped perforated pipeline for delivery of air-water mixture from saturator; 5 – mixing chamber; 6 – flotation chamber; 7 – foam-collecting tray; 8 – scraper; 9 – purified water intake tray.

The impeller method of air dispersion was widely studied with alteration of dimensions, shape and design of the disperser as well as of the rotor speed, depth of its immersion under the waterline and other parameters [5]. The research was carried out both in laboratory and industrial conditions on the waste water of different technological plants. On the grounds of processing of the results thus obtained, a disperser design has been developed having a rational relationship between the main dimensions and a more rational design of an impeller flotator (patented) [6].

Designed in “Stroyengineering SM” L.L.C., the impeller flotator consists (Fig. 8) of three flotation chambers and one thin-layer settling zone wherein the finely-dispersed air bubbles with the absorbed contaminants are emitted. The research has evidenced that bubbles of such size could not be emitted in flotation chambers because of high flow turbulence.

Industrial tests in one of oil refineries have established that with petroleum products concentration in influent water of 130 to 200 g/l, their content in water after flotation with the use of aluminum oxychloride as a coagulant (10 mg/l) did not exceed 25 mg/l and was 15 mg/l on the average.

A higher purification degree is provided by a combined flotator [7] whose design incorporates two types of flotation: impeller and pressure (Fig. 9).

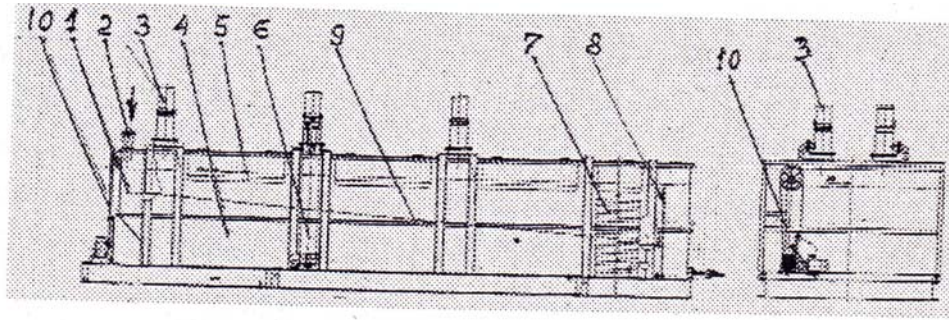

Fig. 8. Impeller flotator, "Stroyengineering SM" L.L.C. 1 – intake chamber; 2 – waste water inlet; 3 – disperser drive; 4 – flotator housing; 5 – foam intake windows; 6 – impeller disperser; 7 – thin-layer unit; 8 – overflow; 9 – foam intake tray; 10 – foam-removing scraper drive

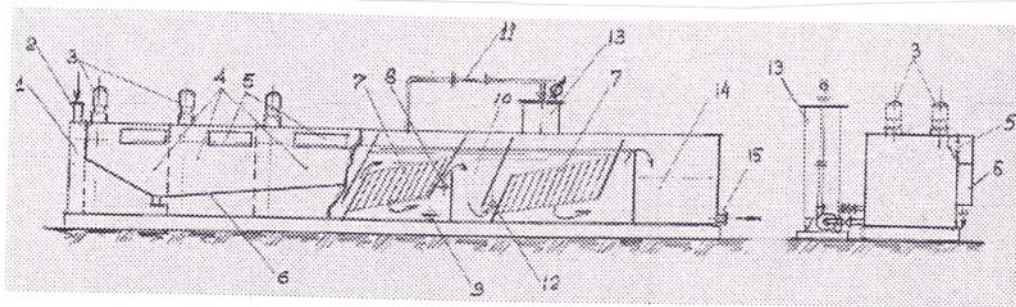

Fig. 9. Combined flotator, "Stroyengineering SM" L.L.C. 1 – intake chamber; 2 – inlet branch pipe; 3 – disperser drives; 4 – flotation chambers; 5 – foam-pouring windows; 6 – foam-collecting tray; 7 – thin-layer units; 8 – reagent feed unit; 9 – water withdrawal unit (for aeration); 10 – chamber for mixing with reagent(s); 11 – ejector; 12 – air-water mixture feed unit; 13 – saturator; 14 – water intake chamber; 15 – purified water outlet

Waste water that has passed the facilities where the coarsely-dispersed contaminants are separated is then delivered to the intake chamber wherein the reagent solution is also supplied. From the intake chamber through the distribution partitions the water successively passes three flotation chambers with the impeller flotators and then goes through the thin-layer settling zone. After this zone the water is taken to the floc formation chamber while a part of the water flow is withdrawn by the pump and fed to the saturator for aeration. Flocculant solution is fed into the remaining flow in front of the floc formation chamber. From the chamber the water is delivered to the zone of mixing with the air-water mixture and then to the thin-layer settling zone after which the water runs over the spillway weir and is removed from the facility.

Industrial use of this facility has demonstrated its high efficiency: residual content of petroleum products was 2 to 3 mg/l at initial concentration of 20 to 25 mg/l.

Flotation process can be successfully applied to solution of problems with many types of waste water. For example, municipal wastewater treatment facilities up to the present day are designed according to old traditional technology: primary sedimentation basins, aeration tanks, secondary sedimentation basins and so on. Meanwhile, a great variety of washing and cleaning means is used in everyday life; besides, there are industrial enterprises being located in towns and having their waste waters with contaminants easily separable by flotation while getting of these contaminants to municipal wastewater treatment

stations is associated with the complication of maintenance and reduction in purification quality. The use of flotation would greatly increase the reliability of wastewater treatment facilities. Moreover, flotators at municipal wastewater treatment stations can both carry out the primary purification function when the water contains fats, food-industry waste etc. and also be used instead of secondary settlers and sludge densifiers. It will allow considerably increasing the efficiency of wastewater treatment stations and reducing the operation costs. However, the contaminants and water phase should be estimated in each particular case.

## References

1. V.G. Ponomarev, E.G. Ioakimis. Formation and purification of waste waters of oil refineries. – Moscow, SOJUZDIZAIN Publishing House (2009).
2. I.N. Myasnikov, V.A. Potanina et al. Improvement of wastewater treatment technology and facilities. Third International Congress "Water, Ecology, Technology". Moscow (1998).
3. Author's Certificate No. 493440, USSR (1975).
4. I.V. Skirdov. Study of water distribution devices influence on operation of radial settling tanks. Thesis work. Moscow (1961).
5. V.G. Ponomarev, I.S. Chuchalin. Study of impeller flotation for purification of oily waste

- waters. Saint Petersburg. "Water and Ecology" magazine, No. 1 (2000).
6. Patent No. 2146228, Russia.
  7. Patent No. 2349553, Russia.

**Prof. Dr. habil. Viktor Georgijevch Ponomarev** – researcher at the Research and Engineering Company "Stroyengineering SM" Moscow, Russia. Former head of the Sewerage Research Laboratory at the research institute "VODGEO" Moscow.

Main research areas: mechanical and physical – chemical waste water treatment, optimization of the industrial waste water treatment and utilization systems.

Address: Str. Ostrovetianova 43,  
Scienmet, Moscow, Russia

Tel.: +790 571 51719

E-mail: [ponovik@mail.ru](mailto:ponovik@mail.ru)

## **Nuotekų valymo flotacija tyrimai ir galimybės**

### **Viktoras Georgijevičius Ponomariovas**

*Inžinerinė kompanija „Stroiinžiniring SM“, Maskva*

*(gauta 2009 m. lapkričio mėn.; atiduota spaudai 2009 gruodžio mėn.)*

Straipsnyje nagrinėjami veiksniai, turintys įtakos nuotekų valymui flotacijos būdu. Autorius daro išvadą, kad vienas iš svarbiausių veiksnių, nuo kurio priklauso flotacijos efektyvumas, yra vandens terpės paviršiaus įtempimas. Aprašoma, kaip šis rodiklis priklauso nuo kitų proceso parametrų. Nagrinėjamos įvairios flotatorių konstrukcijos, atkreipiamas dėmesys į impelerinės flotacijos įrenginių pranašumas.

DOI: 10.5755/j01.erep.50.4.53